

AU

USER MANUAL

EASYLIFT V3 PLUS

AU VS. 10.02

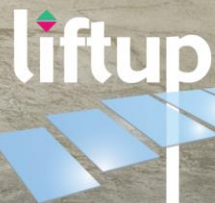

lifting people

Contents

1. Foreword	3
2. Declarations.....	4
2.1 Regulatory Approvals.....	7
2.2 EU declaration of conformity.....	8
3. Factory Acceptance Test (FAT)	9
4. Terms of use	10
5. Technical specifications.....	11
6. Safety instructions.....	14
6.1 Installation, handling and repair.....	14
6.2 Unintended movements of lift.....	14
6.3 Operating conditions	14
6.4 Avoiding personal injury	14
6.5 Overload of the lift.....	15
6.6 Personal safety.....	15
6.7 Anti-crushing.....	15
6.8 Safety barriers.....	16
6.8.1 Ramp as roll-off protection	16
6.8.2 Vertical barrier (optional equipment).....	17
6.8.3 Automatic doors (optional equipment)	17
6.9 Lifts accessible to the public (only certain countries).....	18
6.10 Breakdown/malfunction.....	18
6.10.1 Unlocking the vertical barrier in an emergency.....	18
6.10.2 Unlocking the door in an emergency	19
6.10.3 Emergency lighting/power failure	20
6.10.4 Electrical or mechanical faults/defects.....	20
6.10.5 Emergency evacuation in the event of a malfunction	20
7. Function description.....	21
8. Assembly.....	21
9. Start-up.....	21
10. Instructions for the use	21
10.1 Everyday use	21
10.2 Operating the lift from the UPPER level	23
10.3 Operating the lift from the LOWER level.....	23
10.4 Operating the lift from the platform	23



10.5 Auto return	24
10.6 Emergency stop	24
10.7 ON/OFF switch for the charger	25
10.8 Audible alarms	26
10.9 Alarm and emergency call	27
11. Operation	28
11.1 Battery backup.....	28
11.2 Calibration following emergency stop/power failure.....	28
12. Maintenance.....	29
12.1 Replacement of battery in call stations/remote control	29
13. Pairing transmitter and receiver	31
13.1 Wireless call station/call station column 2.4 GHz.....	31
13.2 Remote control 2.4 GHz (optional equipment)	33
14. Installation and handover.....	35
15. Inspection, checks and service inspections.....	36
15.1 Statutory inspection and checks.....	36
15.2 Regular service inspections.....	36
15.3 Service report for use in service inspections	37
15.4 Service logbook.....	38
15.5 Online service log (only certain countries)	39
16. Spare parts and accessories	40
17. Disassembly	43
18. Disposal	43
18.1 Material specification for EasyLift	43
19. Right of complaint	44

September 2024



1. Foreword

Congratulations on purchasing your new EasyLift lifting platform.

This is an original user manual for your new EasyLift V3 PLUS. Hereinafter we use the term EasyLift for EasyLift V3 PLUS, if nothing else is specifically indicated.



IMPORTANT!

It is important to read the entire user manual before using the lift

Set-up and installation **MUST** be undertaken by a qualified Liftup service technician, to ensure correct assembly. Improper assembly can lead to unintended risks of personal injury.

EasyLift is a lifting platform for wheelchairs, offering users easy and stylish access between two levels. The lift is easy to operate using operating panels mounted on the wall, on the lifting platform, or by means of a remote control.

In this user manual “EasyLift lifting platform” will be mentioned as “lift”.

Where an “authorized service technician” is referred to below, this refers to a service technician who has completed a product and service course at Liftup.

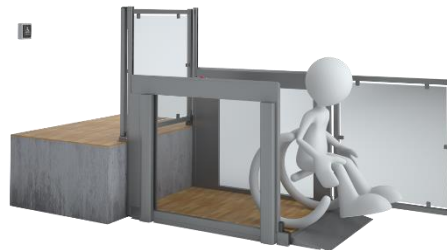
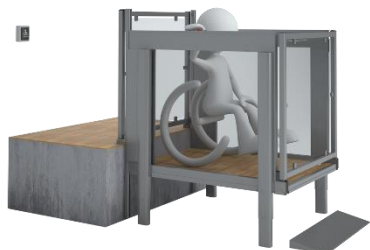

2. Declarations

Manufacturer: Liftup A/S
Address: Hagensvej 21, DK-9530 Støvring, Denmark
Telephone no.: +45 9686 3020

Copyright and Trademarks

© Liftup A/S. All rights reserved.

Liftup, the Liftup logo and Liftup are trademarks of Liftup A/S, registered in the United States and in other countries. All other trademarks are the property of their respective owners.

The following Product Limited Warranty gives Resellers specific legal rights. You may have others, which vary from state/jurisdiction to state/jurisdiction.

Product Limited Warranty

Subject to the terms and conditions set forth herein, Liftup A/S (“Liftup”) makes the following warranty only to its Resellers who purchase the EasyLift V3 PLUS product (“Product”) directly from Liftup: for a period of one (1) year from the date of shipment from Liftup, the Product will substantially conform to Liftup’s standard published specifications for the Product and the Product hardware will be substantially free from defects in materials and workmanship. The foregoing warranty shall not apply to embedded software/firmware components.

THIS PRODUCT LIMITED WARRANTY IS PROVIDED TO RESELLERS AND TO RESELLERS ONLY. RESELLER IS SOLELY RESPONSIBLE FOR ANY AND ALL WARRANTIES MADE TO ITS CUSTOMERS, AND LIFTUP MAKES NO WARRANTIES, EXPRESS OR IMPLIED, AND SHALL HAVE NO OBLIGATIONS OR LIABILITY TO RESELLER’S CUSTOMERS OR END-USERS OF THE PRODUCT. RESELLER SHALL NOT MAKE ANY REPRESENTATIONS OR WARRANTIES ON LIFTUP’S BEHALF, AND SHALL FULLY INDEMNIFY, DEFEND AND HOLD LIFTUP HARMLESS FROM ANY BREACH OF THE FOREGOING. IF RESELLER DISTRIBUTES PRODUCT TO END-USER CUSTOMERS, RESELLER SHALL BE SOLELY RESPONSIBLE FOR PREPARING AND PROVIDING PRODUCT WARRANTIES AND PRODUCT LITERATURE TO END-USERS.

Warranty Remedies

If the Product fails during the warranty period for reasons covered by this Product Limited Warranty and Reseller notifies Liftup of such failure during the warranty period, Liftup is at option to repair OR replace the nonconforming Product, OR refund the purchase price paid by Reseller for the Product, provided that Reseller returns the Product to Liftup in accordance with Liftup’s standard return material authorization procedures or as otherwise instructed by Liftup.

Warranty Exclusions and Disclaimers

The foregoing Product Limited Warranty shall only apply in the event and to the extent that (i) the Product is properly and correctly installed, configured, interfaced, maintained, stored and operated in accordance with Liftup’s specifications, and (ii) the Product is not modified or misused. This Product Limited Warranty shall not apply to, and Liftup shall not be responsible for, defects or performance problems resulting from: (a) the combination or utilization of the Product with hardware or software products, information, data, systems, interfaces, services or



devices not made, supplied or specified by Liftup; (b) the operation of the Product under any specifications other than, or in addition to, Liftup's standard published specifications for the Product; (c) the unauthorized installation, modification or use of the Product; (d) damage caused by: accident, lightning or other electrical discharge, water immersion or spray, or exposure to environmental conditions for which the Product is not intended; or (e) normal wear and tear on consumable parts, including by way of example and without limitation, batteries.

LIFTUP DOES NOT WARRANT OR GUARANTEE THE RESULTS OBTAINED THROUGH THE USE OF THE PRODUCT. THE FOREGOING TERMS OF THE PRODUCT LIMITED WARRANTY STATE LIFTUP'S ENTIRE LIABILITY, AND RESELLER'S EXCLUSIVE REMEDIES, RELATING TO THE USE AND PERFORMANCE OF THE PRODUCT EXCEPT AS OTHERWISE EXPRESSLY PROVIDED FOR IN THIS PRODUCT LIMITED WARRANTY, THE PRODUCT, ACCOMPANYING DOCUMENTATION AND MATERIALS, AND/OR ANY EMBEDDED SOFTWARE/FIRMWARE AND UPDATES THERETO ARE PROVIDED "AS-IS" AND WITHOUT EXPRESS OR IMPLIED WARRANTIES OF ANY KIND, BY EITHER LIFTUP OR ANYONE WHO HAS BEEN INVOLVED IN ITS CREATION, PRODUCTION, INSTALLATION OR DISTRIBUTION, INCLUDING, BUT NOT LIMITED TO, THE IMPLIED WARRANTIES OF MERCHANTABILITY AND FITNESS FOR A PARTICULAR PURPOSE, TITLE AND NONINFRINGEMENT. THE STATED EXPRESS WARRANTIES ARE IN LIEU OF ALL OBLIGATIONS OR LIABILITIES ON THE PART OF LIFTUP ARISING OUT OF, OR IN CONNECTION WITH, THE PRODUCT. WITHOUT LIMITING THE GENERALITY OF THE FOREGOING:

THE PRODUCT MAY CONTAIN TECHNOLOGY THAT IS NOT FAULT TOLERANT AND IS NOT DESIGNED, MANUFACTURED OR INTENDED FOR USE IN ENVIRONMENTS OR APPLICATIONS IN WHICH THE FAILURE OF THE PRODUCT WOULD LEAD TO DEATH, PERSONAL INJURY OR SEVERE PHYSICAL OR ENVIRONMENTAL DAMAGE OR SEVERE FINANCIAL LOSS. ANY USE OR DISTRIBUTION BY RESELLER OR ITS CUSTOMERS IN CONNECTION WITH ANY SUCH ENVIRONMENT OR APPLICATION SHALL BE AT RESELLER'S AND ITS CUSTOMERS' SOLE RISK, AND LIFTUP SHALL HAVE NO LIABILITY WHATSOEVER IN CONNECTION THEREWITH. RESELLER SHALL INDEMNIFY AND HOLD LIFTUP AND ITS SUPPLIERS HARMLESS FROM ANY CLAIM BROUGHT AGAINST LIFTUP WHICH ARISES FROM RESELLER'S USE OR DISTRIBUTION OF THE PRODUCT IN CONNECTION WITH SUCH ENVIRONMENTS OR APPLICATIONS. SOME STATES AND JURISDICTIONS DO NOT ALLOW LIMITATIONS ON DURATION OR THE EXCLUSION OF AN IMPLIED WARRANTY, SO CERTAIN OF THE ABOVE LIMITATIONS MAY NOT APPLY TO EVERY RESELLER.

Embedded Software/Firmware

The Product and associated tools, if any, may contain embedded software/firmware, which is licensed, not sold, and is only for use within the Product as an integral part thereof. Such embedded software/firmware (which includes all updates thereto) contains valuable trade secrets and is proprietary to Liftup A/S and its suppliers. To the greatest extent permitted by law, such embedded software/firmware may not be modified, copied, disassembled, decompiled or reverse engineered. Liftup reserves all other rights.

Limitation of Liability

LIFTUP'S ENTIRE LIABILITY REGARDING THE PRODUCT SHALL BE LIMITED TO THE AMOUNT ACTUALLY PAID BY RESELLER FOR THE PRODUCT. TO THE MAXIMUM EXTENT PERMITTED BY APPLICABLE LAW, IN NO EVENT SHALL LIFTUP OR ITS SUPPLIERS BE LIABLE FOR ANY INDIRECT, SPECIAL, INCIDENTAL OR CONSEQUENTIAL DAMAGES WHATSOEVER UNDER ANY CIRCUMSTANCE OR LEGAL THEORY RELATING IN ANY WAY TO THE PRODUCTS, ACCOMPANYING



DOCUMENTATION AND MATERIALS, AND ANY EMBEDDED SOFTWARE/FIRMWARE AND UPDATES THERETO (INCLUDING, WITHOUT LIMITATION, DAMAGES FOR LOSS OF BUSINESS PROFITS, BUSINESS INTERRUPTION, LOSS OF DATA OR ANY OTHER PECUNIARY LOSS), REGARDLESS OF WHETHER LIFTUP HAS BEEN ADVISED OF THE POSSIBILITY OF ANY SUCH LOSS AND REGARDLESS OF THE COURSE OF DEALING BETWEEN LIFTUP AND RESELLER. BECAUSE SOME STATES AND JURISDICTIONS DO NOT ALLOW THE EXCLUSION OR LIMITATION OF LIABILITY FOR CONSEQUENTIAL OR INCIDENTAL DAMAGES, THE ABOVE LIMITATION MAY NOT APPLY TO EVERY RESELLER.

Notices

Class B Statement – Notice to Users. This equipment has been tested and found to comply with the limits for a Class B digital device, pursuant to Part 15 of the FCC rules. These limits are designed to provide reasonable protection against harmful interference in a residential installation. This equipment generates, uses, and can radiate radio frequency energy and, if not installed and used in accordance with the instructions, may cause harmful interference to radio communication. However, there is no guarantee that interference will not occur in a particular installation. If this equipment does cause harmful interference to radio or television reception, which can be determined by turning the equipment off and on, the user is encouraged to try to correct the interference by one or more of the following measures:

- Reorient or relocate the receiving antenna.
- Increase the separation between the equipment and the receiver.
- Consult the dealer or an experienced radio/TV technician for help.

Changes and modifications not expressly approved by the manufacturer or registrant of this equipment can void your authority to operate this equipment under Federal Communications Commission rules.



2.1 Regulatory Approvals

FCC/IC

The radio module contained in the EasyLift V3 PLUS and associated remote comply with the FCC Part 15.249 and the Industry Canada requirements RSS-GEN, RSS-210

The radio module contained in the EasyLift V3 PLUS and associated remotes complies with Part 15 of the FCC rules and with Industry Canada license exempt standard(s). Operation is subject to the following two conditions:

- (1) This device may not cause harmful interference, and
- (2) This device must accept any interference received, including interference that may cause undesired operation.

The radio module contained in the EasyLift V3 PLUS and associated remotes are SAR test excluded according to FCC KDB 447498, RSS102 and EN 62479 at separation distances larger than 5 mm and less than 50 mm.

With respect to radio frequency radiation exposure Information, it is declared; that this equipment complies with FCC radiation exposure limits set forth for an uncontrolled environment. This gives an extra margin, since the remote control normally, only is used in “controlled environment” for approx. 30 seconds when lifting, and typically only a few times a day.

EasyLift V3 PLUS contains:	Handheld REMOTE1	Wall mounted REMOTE2:
FCC ID: 2AK8H-MODULE1	FCC ID: 2AK8H-REMOTE1	FCC ID: 2AK8H-REMOTE2
IC: 22516-MODULE1	IC: 22516-REMOTE1	IC: 22516-REMOTE2

EU Declaration of Conformity: CE
(Machinery Directive and RED (Radio module and remote))

ASME A18.1 2020 (US/FDA)

The EasyLift V3 PLUS complies with key requirements of the ASME 18.1 Safety Standard for Platform lifts and Stairway Chairlifts, section 5 “Private Residence Platform Lifts”. Please note that not all possible configurations of the EasyLift V3 PLUS are in compliance – consult your reseller for further information.



2.2 EU declaration of conformity

Manufacturer: Liftup A/S
Address: Hagensvej 21, DK-9530 Støvring, Denmark
Telephone: +45 9686 3020



hereby declares that:

Equipment: **EasyLift V3 PLUS**
Lifting platform for wheelchair users and persons with impaired mobility

Year: 2019

The equipment complies with important requirements in the CE Marking Directives:

The Machinery Directive:	2006/42/EC
The Electromagnetic Compatibility Directive (EMC):	2014/30/EU
Restriction on Hazardous Substances (RoHS):	2011/65/EU
The Radio Equipment Directive (RED):	2014/53/EU

The equipment complies with requirements based on the following standards:

DS/EN 60204	Safety of machinery – Electrical equipment of machines.
DS/EN 13849-1 and -2	Safety-related parts of control systems

_____ CEO Position	_____ Søren Elisiussen Name
_____ Liftup A/S, Hagensvej 21, DK-9530 Støvring, Denmark Place	
_____ 2 September 2019 Date	_____  Signature



3. Factory Acceptance Test (FAT)



FACTORY ACCEPTANCE TEST

Certificate

is hereby issued to EasyLift V3 PLUS with serial no.

(insert serial number / copy of CE certification mark here)

The validity of the CE certificate is subject to correctly performed installation, cf. the manufacturer's instructions.

To certify that all safety tests, performance tests and other tests specified by our certified ISO 9001:2015 Quality Management System have been successfully passed and documented.

Issue date

Test responsible

Liftup A/S | Hagensvej 21 | 9530 Støvring | Denmark
T: +45 96 86 30 20 | M: mail@liftup.dk
www.liftup.dk | CVR: DK-1015 3964



4. Terms of use

The lift is exclusively for the use of wheelchair users and persons with impaired mobility.



It is important to read the entire user manual before using the lift



IMPORTANT!

The lift must NOT be used for goods transport, including loaded pallets or other types of heavy loads.



The owner of this lift is obliged to maintain it according to the Maintenance guide (see section 12).



Do not dispose of batteries, electrical or electronic equipment with unsorted household rubbish. When disposing of this device, ensure compliance with local ordinances and regulations.



Max 750 lbs
Max 340 kg

EasyLift 800/900 V3 PLUS

The maximum load is 750 lbs/340 kg **evenly distributed on the lift** (max. 2 persons)



Max 880 lbs
Max 400 kg

EasyLift 1100 V3 PLUS

The maximum load is 880 lbs/400 kg **evenly distributed on the lift** (max. 2 persons)

If the lift is accessible to the public, it is the responsibility of the owner to ensure that statutory inspections, checks and service inspections are performed in accordance with the legal provision and at correct intervals, and that necessary safety equipment is provided for.



5. Technical specifications

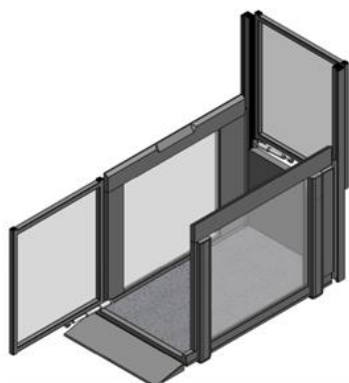

EasyLift 800/900 V3 PLUS

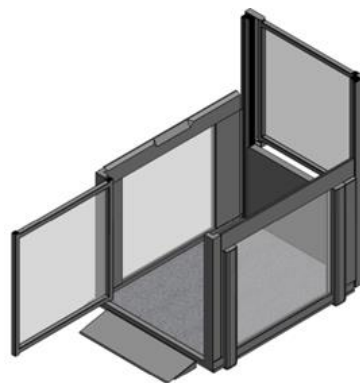

EasyLift 1100 V3 PLUS



All scale drawings for EasyLift V3 PLUS are available at Liftup Product Configurator: www.liftup.dk/lpc

Specifications:

Power:	90 – 305V-AC / 1,67 A / 60 W	
Indoors:	100 - 240V / 50 Hz (1,1A) Max: 90w, Standby < 6w	
Outdoors:	90 – 305V-AC / 47 - 63 Hz / 1,67 A / 60 W	
Lifting capacity:		
EasyLift 800/900 V3 PLUS:	750 lbs (340 kg)	
EasyLift 1100 V3 PLUS:	880 lbs (400 kg)	
Lifting height:	70 – 1250 mm	(2,76 – 49.21")
Platform size:		
Internal dimensions:	W 800/900/1100 mm	(31.50/35.43/39.37")
	L 1400 mm	(55.12")
External dimensions:		
EasyLift 800/900 V3 PLUS:	W 960/1060 mm	(37.8/41.73")
	L 1750 mm	(68.9")
EasyLift 1100 V3 PLUS:	W 1260 mm	(49.61")
	L 1820 mm	(71.65")
Dead weight:		
EasyLift 800/900 V3 PLUS:	approx. 440 lbs (200 kg)	
EasyLift 1100 V3 PLUS:	approx.. 550 lbs (250 kg)	
Noise level:	< 70 dB ¹⁾	
	¹⁾ The noise level is an average, and for a short period noise will occur > 70 dB	
Water and dust:	>50V: IP67 (Power Supply) / <50V: IP23 / <10V: IPxx	



Lifting speed/ temperature:	°F	°C	in/sec	mm/sec
	+104°F - 41°F	+40 °C - +5 °C:	1.57"	40 mm
	+41°F - 23°F	+5 °C - -5 °C:	0.79"	20 mm
	+23°F - -4°F	-5 °C - -20 °C:	0.39"	10 mm
Max. 440 lbs/200 kg	-4°F - -13°F	-20 °C - -25 °C:	0.39"	10 mm

Approval:	Directive 2006/42/EC on machinery
Duty cycle:	2 min. / 5 min.
Battery capacity:	30 cycles at 25°C
Flat battery:	10 min. charge = one trip Fully charged = 5 hours

All radio components comply with the following regulations and standards:

EU	2014/53/EU, Radio Equipment Directive (RED)
FCC (USA)	CFR 47 Part 15
EN 62479:2010	Human exposure
EN 300 440, v2.1.1	Electromagnetic compatibility + Radio spectrum Matters Draft
EN 301489-1, v2.2.0	Electromagnetic compatibility + Radio spectrum Matters Draft
EN301489-17, v3.2.0	Electromagnetic compatibility + Radio spectrum Matters
AS/NZS 4268	Radio Equipment and Systems –Short Range devices
AS/NZS 2772.2	Radio Frequency Fields (mean power < 1 mW)

Internal receiver in EasyLift (MODULE1)

2,4 GHz Short Range devices. FCC ID: 2AK8H-MODULE1

Receiver Class 3

Dimensions (L x W x H):	72 x 33 x 10mm / 2,83 x 1,30 x 0,40 in.
Weight:	10 g (0,035 lbs.)
Frequencies:	2,410 GHz 2,435 GHz and 2,460 GHz
Duty cycle:	< 1% (only TX for pairing Remotes)
Power:	< 0,6mW Controlled environment
Supply:	5,6 Volt 30mA
Water and dust:	IP XX (shall be mounted inside Liftup products)
Working temperature:	+5°C to +40°C/ 41°F to 104°F
Storage temperature:	-25°C to +70°C / 13°F to 158°F
Expected service life:	> 5 years

Handheld wireless remote control (REMOTE1)

2,4 GHz Short Range devices. FCC ID: 2AK8H-REMOTE1

Receiver Class 3

Dimensions (L x W x H):	96 x 47 x 24mm / 3,79 x 1,85 x 0,95 in.
Weight:	48 g (0,11 lbs.)
Frequencies:	2,410 GHz 2,435 GHz and 2,460 GHz
Duty cycle:	< 1%
Power:	<0,6mW Controlled environment, Hold to run
Battery:	3 Volt CR2032
Water and dust:	IP 42
Working temperature:	+5°C to +40°C / 41°F to 104°F
Storage temperature:	-25°C to +70°C / 13°F to 158°F
Expected service life:	> 5 years



Wall-mounted wireless call station (REMOTE2)

2,4 GHZ Short Range devices FCC ID: 2AK8H-REMOTE2

Receiver Class 3

Dimensions (L x W x H): 170 x 72 x 42mm / 6.70 x 2.83 x 1.65 in.

Weight: 180-215 g / 0.4-0.47 lbs.

Frequencies: 2,410 GHz 2,435 GHz and 2,460 GHz

Duty cycle: < 1%

Power: < 0,6mW Controlled environment, Hold to run.

Battery: 3 Volt CR2032

Water and dust: IP 54

Working temperature: +5°C to +40°C/ 41°F to 104°F

Storage temperature: -25°C to +70°C / 13°F to 158°F

Expected service life: > 5 years

Right reserved to make technical modifications.



6. Safety instructions

6.1 Installation, handling and repair

Do not attempt to install or repair the lift yourself. This MUST be done by an authorized service technician. Do NOT remove the protective plates or safety plates, as this could lead to the lift causing personal injury.

The lift is normally supplied by your dealer who will also be responsible for the installation.



WARNING!

Do not try to move the lift manually, as this can lead to personal injury. The product should be moved and handled using suitable lifting equipment (pallet truck, roller plate, or similar). Do not expose the lift to heavy bumps or jolts as this can damage its functionality.

6.2 Unintended movements of lift

If during the use of your lift movement or action occurs which is not described in this manual, stop the unit and call technical assistance.

Should your lift not move with a plane movement as a lifting platform, calibrate it by running it down to floor level. If the problem continues, call technical assistance.

6.3 Operating conditions

The space under the lift must be kept free of all objects, which may impair its downward movement. Otherwise, the lift cannot be moved down to the lower level and thus cannot fulfil its function as a lifting platform.

If an object/material prevents the lift moving in a downward direction, the lift will suspend its movement, issue an audible alarm and move upwards 2-3 cm automatically. This will allow the object to be removed. The object or material must be removed before the lift may be used again.

6.4 Avoiding personal injury

In order to avoid personal injury, users may NOT use the lift when someone or something is at risk of injury through crushing, cutting, falling, tripping or the like. The user/operator shall strive to the greatest extent possible to ensure that the lift can move without risk of causing injury.

Be extra careful when small children and disabled persons are on or around the lift, since these groups cannot always be expected to be able to foresee the possible consequences of the lift movements.



6.5 Overload of the lift

In order to avoid damage to equipment due to overloading (max. 750 lbs/340 kg (EasyLift 800/900 V3 PLUS) or 880 lbs/400 kg (EasyLift 1100 V3 PLUS) evenly distributed), the lift is fitted with overload protection which stops the lift and issues an audible alarm if overload occurs. In the event of overload, run the lift downward to exit.

6.6 Personal safety

The lift is fitted with various safety features which ensure that the user or other people are not injured when using the lift.



WARNING!

Although the lift comes fitted with various safety features, never use it if persons or animals are close by, as there may otherwise be a risk of crushing.

Never allow children to play with the lift.

6.7 Anti-crushing

Beneath the entire lift a number of push plates (anti-crushing) are fitted which are activated if an object is going to be crushed below. When this feature is activated, the lift stops and then runs approx. 2 cm upwards, while at the same time an audible alarm is issued (see section 10.8).

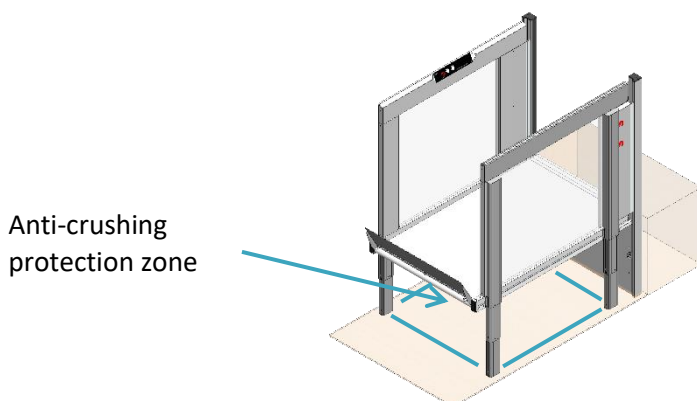

If the anti-crushing feature is activated, release the operating button. Remove any objects under the lift and then again run it to floor level. (If needed, move the lift up a small distance so you can easily remove objects from under it).

IMPORTANT!



Keep in mind that when the lift is used outdoors, leaves, branches and snow can affect the anti-crushing safety feature, and so you should check regularly that the lift will not be obstructed when moving downward.

For outdoor installations we recommend returning the lift to ground level after use, in order to prevent unwanted objects finding their way under the lift



6.8 Bellows (optional equipment)

The lift can be delivered with a bellows, so that the area under the lift is shielded.



IMPORTANT!

When the lift is installed outdoors, care must be taken that leaves, gravel, etc. can clog the drain in the pit. Therefore, it should be regularly checked that the drain is not blocked.



IMPORTANT!

For installations with bellows, it is recommended to run the lift down after use, as this will protect the bellows and extend its life. If possible, activate the auto return function on the lift so that it travels to the lowest level, cf. section 10.5.

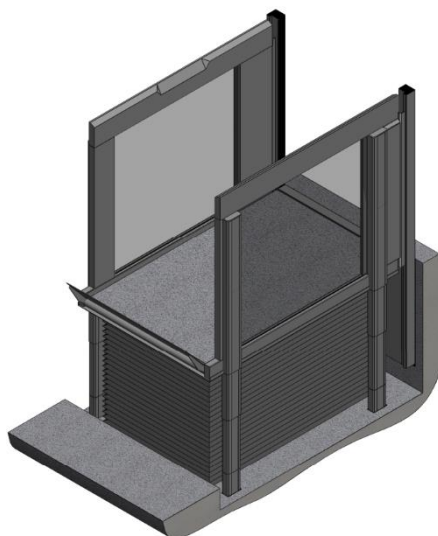

6.9 Safety barriers

6.9.1 Ramp as roll-off protection

If the lift is fitted with a ramp, the ramp will first pull up and lock before the lift begins to move. The ramp now acts as roll-off protection. When the lift returns to floor level, the ramp will automatically lower (keep the button pressed) and act as a drive-on/drive-off ramp.

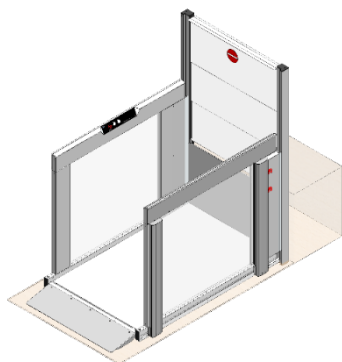

Drive-on/drive-off ramp

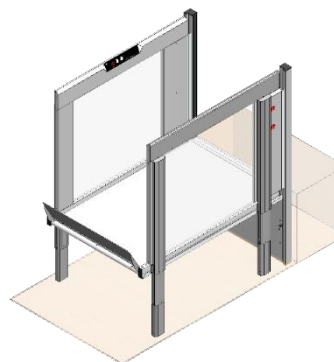

Ramp as roll-off protection



6.9.2 Vertical barrier (optional equipment)

If the lift is fitted with a vertical barrier at the upper level, it will close before the lift begins to move. The vertical safety barrier will always be closed, when the lift is not at the upper level.

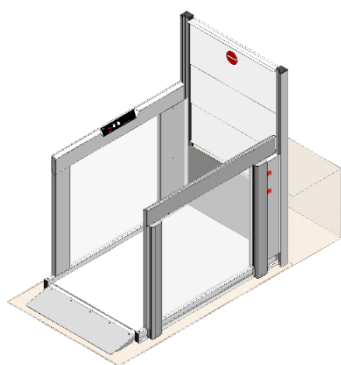

Lower level

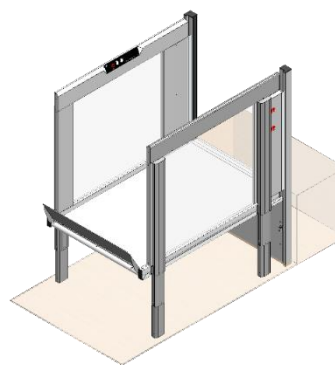

Upper level

6.9.3 Automatic doors (optional equipment)

If the lift is fitted with automatic doors, they will close, and the door motor will be in a locked position before the lift starts to move. The doors will always be closed when the lift has moved off ground level.

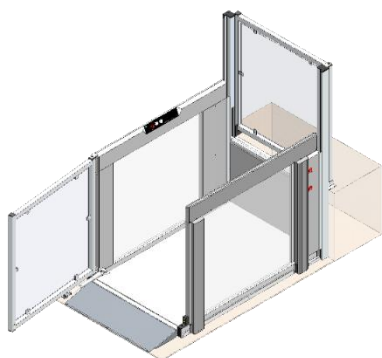

Lower level

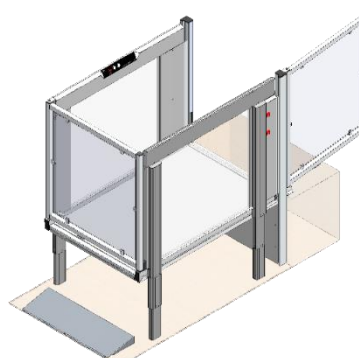

Upper level

If the lift is fitted with doors, they can be equipped with automatic door locks (only available on EasyLift 1100 V3 PLUS). The automatic door locks will secure that the doors are locked before the lift begins to move.

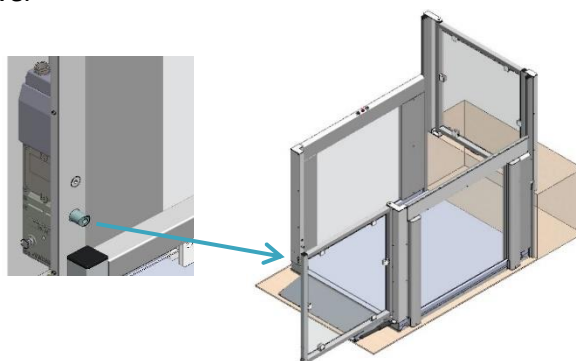

IMPORTANT!

Strong wind may disturb the functionality of the door.



6.10 Lifts accessible to the public (only certain countries)

If the lift is accessible to the public, basically it must be equipped with a key switch, ensuring that the lift can be locked when left unobserved.

In order to make sure that persons cannot unintendedly be trapped in the lift, it must be possible to lock it so that it is not possible to access the lift (in a normal manner). The key switch shall prevent the lift from moving and ensure that doors may be closed or locked. If the lift is not under observation or locked, but the owner (or his representative) is present close to the building, it must be equipped with an alarm signal for calling for help.

If the lift is equipped with an alarm signal, the signal must be connected to an external alarm device (e.g. light, sound or similar) which can draw attention to the need for assistance at the lift. If the lift is installed in such a way that an alarm signal is insufficient (e. g. freely accessible without observation), a two-way communication system must be installed.

If the lift is installed with a two-way communication system, it must be connected to a telephone number which is in operation at any time (when the lift is accessible).

6.11 Breakdown/malfunction

6.11.1 Unlocking the vertical barrier in an emergency

In the event of an emergency/breakdown: Slowly press down the barrier.

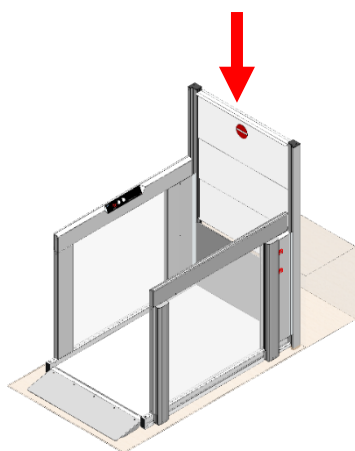

WARNING!

If you push too quickly, the barrier motor may be ruined.



6.11.2 Unlocking the door in an emergency

In case of an emergency/malfunction: **Release the** folding spring bolt.

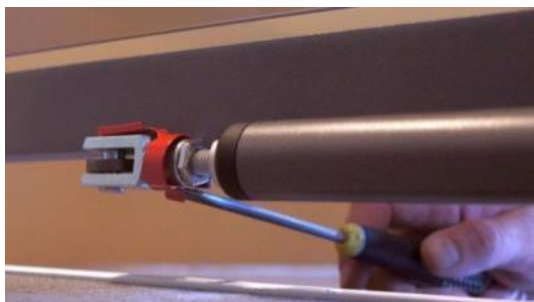

1. Pull the spring out from the shaft of the clevis, using a suitable tool, screwdriver, ruler, bottle-opener, etc.



2. From outside, you can approach the lower side



3. The spring is released



4. When the spring is released pull out the bolt.



NOTE:

The bolt may be difficult to pull out, because of pressure on the door actuator.



5. Now the door can be moved freely



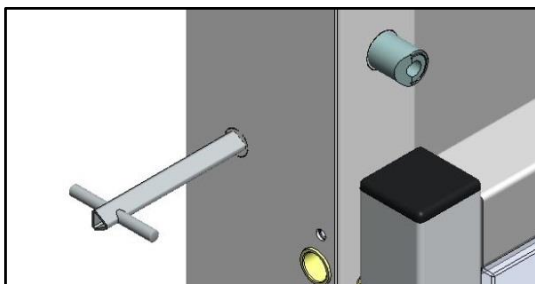

6. If the door is equipped with an automatic door lock, unlock it with a triangular key (automatic door lock is only available on EasyLift 1100 V3 PLUS).

When the fault has been corrected, the door can be connected again following this instruction in reverse order.

6.11.3 Emergency lighting/power failure

In the event of power failure or if the power supply to the lift's controls is interrupted for some reason, the system will automatically shift to back-up mode. This means that the system will continue to operate because the lift will then be supplied by a back-up battery. The operating panel will continue to be lit up. An acoustic alarm alerts the user that the lift is not in a 'normal operating situation'.



6.11.4 Electrical or mechanical faults/defects

In the event of (certain) mechanical or electrical faults, the lift will automatically enter into a special "safety mode", that only allows it to moved downward at low speed. It is not possible to move upward, see section 11.2.

6.11.5 Emergency evacuation in the event of a malfunction

In the event of other (serious) faults where the lift cannot be lowered in "safety mode" (slow, downward operation), only a service technician will be able to make the lift move by means of a special "service mode" to which the user does not have access. It is not possible to lower the lift manually, but the user can be helped off of the lift manually in such an event by virtue of the low lift height (max. 1200 mm). If a user needs to be lifted off of the lift (e.g., a wheelchair user) suitable lifting equipment/aids should be used.

The vertical barrier or door at the upper level can be opened to allow access to the lifting platform (see description above). Lift installations that are not under constant supervision can be equipped with an alarm.



7. Function description



The lift is a so-called “Hold to run” lift, i.e., the push buttons must be pushed in throughout the entire operation.

The lift is easy to operate: The user summons the lift using one of the buttons on the wall/the call station column, or the accompanying remote control (optional equipment).

When the user is on the platform, it is operated from the panel on the side, from where transport to the upper or lower level is selected.

8. Assembly

The lift installation must be undertaken by an authorized service technician. Do not attempt to move, disassemble, or repair your lift. These actions **MUST** be performed by an authorized service technician.

Improper assembly may increase the risk of user injury. Liftup is exempt from any liability if assembly and installation are not performed by an authorized service technician.

For more information or materials on assembly, you may contact your dealer, cf. <https://www.liftup.dk/en/contact>.

9. Start-up

The lift must always be connected to a 100-240V power point and be powered on. Under normal circumstances the lift is always in stand-by mode, i.e. it is ready for use as soon as one of the operating buttons is pressed.

If the emergency stop button is pressed, or the lift has been disconnected through the key switch, this must be deactivated before the lift can be used (find out more in section 10).

10. Instructions for the use

10.1 Everyday use

The lift can be activated and operated by means of the operating panel on the platform (fig.1), a remote control (optional equipment) (fig. 10) or operating panels on the upper and lower levels respectively: Standard call stations (figs. 2-5), call station columns (figs. 6-9), or the key-operated call stations (fig. 11). In addition, the lift can be turned on and off by means of a key switch (optional equipment) (fig. 12).



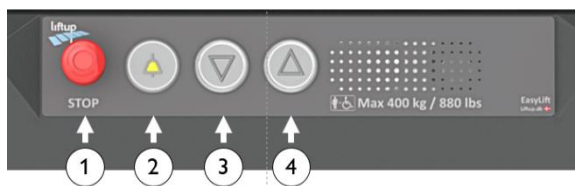

1. Emergency stop
2. Alarm button (optional equipment)
3. Moving the lift down
4. Moving the lift up

Fig. 1: Operating panel on the lift



Fig. 2: Standard call station with cable, 1-way



Fig. 3: Standard call station with cable, 2-way



Fig. 4: Standard call station, wireless, 1-way



Fig. 5: Standard call station, wireless, 2-way

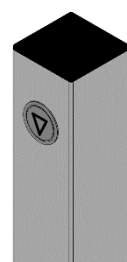

Fig. 6: Call station column with cable, 1-way

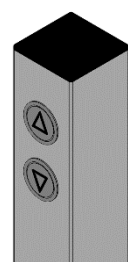

Fig. 7: Call station column with cable, 2-way

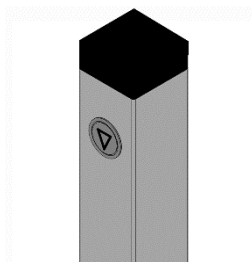

Fig. 8: Call station column wireless, 1-way

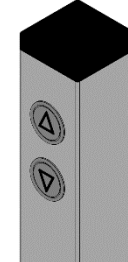

Fig. 9: Call station column wireless, 2-way



Fig. 10: Remote control (optional equipment)



Fig. 11: Key-operated call station

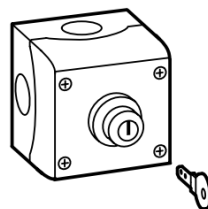

Fig. 12: key switch ON/OFF (optional equipment)



10.2 Operating the lift from the UPPER level



The lift is activated from the UPPER level by pressing and holding in the arrow button (▲) on the operating panel.

The platform then moves to the upper level and the barrier/door at the upper level is opened so that access is given to the platform.

Drive onto the platform carefully and lock/brake the wheelchair.

Press and hold the arrow button (▼), upon which the platform will move down to the LOWER level. When the platform has reached the lower level, the door will open and/or the roll-off protection is lowered to work as a drive-on/drive-off ramp. Drive away from the platform carefully.



After approx. 60 sec. (standard programming) the platform will automatically close the door/ramp.

10.3 Operating the lift from the LOWER level



The lift is activated from the LOWER level by pressing and holding in the arrow button (▼) on the operating panel.

When the platform reaches the lower level, the roll-off protection is lowered and acts as a drive-on/drive-off ramp. Drive onto the platform carefully and lock/brake the wheelchair.

Press and hold in the arrow button (▲). The platform then moves to the UPPER level and the barrier/door at the upper level is opened so that it is possible to exit at the UPPER platform. Drive away from the platform carefully.



After approx. 60 sec. (standard programming) the platform will automatically close the door/upper barrier.

10.4 Operating the lift from the platform

Three buttons are available on the lift (see Fig. 1) – one with an UP arrow (▲), one with a DOWN arrow (▼), and an emergency stop button (●).



When you are on the lift and wish to ascend to the upper level, press the up button. The ramp or the doors will close, and the lift will start to move upward. Hold down the button until you have reached the upper level, the lift has come to a stop and the barrier/doors have fully opened. You can now exit the lift.



When you are on the lift and wish to access the lower level, press and hold the down button. The doors will close, and the lift will start to move downward. Keep the button pressed until you have reached the ground level, the lift has come to a stop and the ramp/doors have fully opened. You can now exit the lift.



10.5 Auto return

The auto return function can be activated by an authorized service technician via the Liftup Service Tool.



IMPORTANT!

Your authorized service technician can ascertain whether the automatic operation of the lift is permitted, depending on the legislation in the country in question.

With the auto return function, the lift automatically closes the door and moves back to the upper/lower level if no operating buttons or IR sensors have been activated for approx. 60 seconds (standard programming).

An acoustic alarm will be sounded during this operation (see section 10.8).

10.6 Emergency stop



If the lift makes an unintended or undesired movement, or if it must be stopped in order to avoid potential risks, press the EMERGENCY STOP button.

To release the emergency stop, turn the button clockwise and the system is again ready for use.



10.7 ON/OFF switch for the charger

The lift has an ON/OFF switch for the charger. The switch is used to disconnect the power from the charger to the lift. If the switch is set to OFF, the lift runs on the batteries only. If the switch is set to OFF and the emergency stop is activated at the same time, also the power supply from the batteries to the lift will be disconnected. After approx. 10 seconds the lift turns off.

The ON/OFF switch for the charger is used for example in connection with service and maintenance work.

When the power supply from the charger is reconnected (ON), and the emergency stop is released, the control system restarts (see section 11.2). The switch is normally set to ON so as not to damage the batteries.



WARNING!

The ON/OFF switch can disconnect the power supply from the charger to the lift. It is not the mains. If it is set to OFF over a longer time-span, it may drain and damage the batteries. In the event of a long-standing power outage, the emergency stop should be activated to ensure that the batteries are not completely discharged.

The switch is sited at the bottom right-hand side of the lift. The cover must be removed to access the switch.

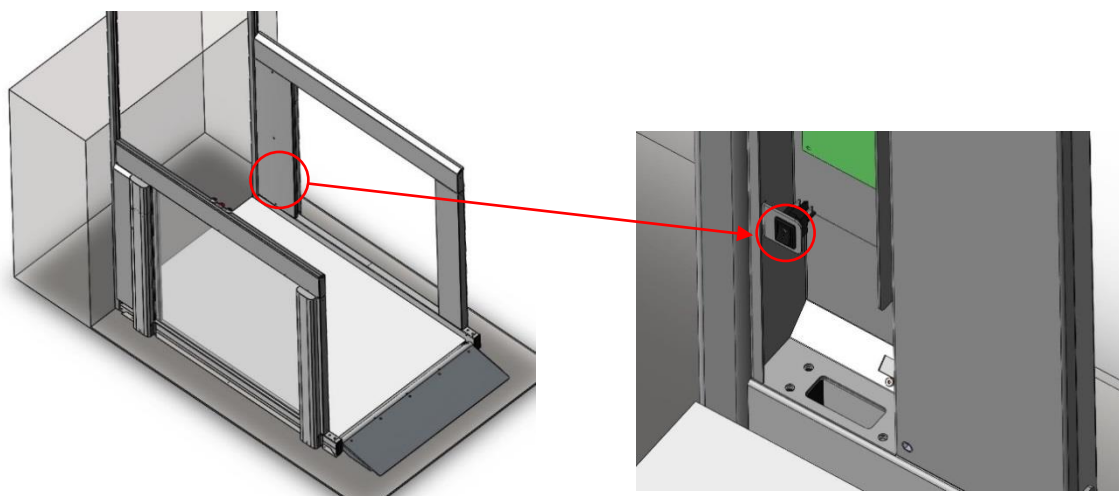

10.8 Audible alarms

Speak	Activity/warning	
Opening	The vertical safety barrier is opening	■ ■ ■ ■
Closing	The vertical safety barrier is closing	■ ■ ■ ■
Alarm: Overload alarm	The platform is overloaded	■ ■ ■ ■ ■ ■ ■ ■
Alarm: Battery fault – the lift cannot be used	The battery has a fault. Inadequate power supply. Cf. section 5 (Technical Specifications)	■ ■ ■ ■ ■ ■ ■ ■ ■ ■
Alarm: Something is under the lift d	Remove the object under the lift which is preventing downward movement	■ ■ ■ ■ ■ ■ ■ ■
Ding Ding Ding	Arriving at upper/lower level	
Warning – automatic operation	A warning before the lift will run auto return	
BEEP-BEEP-BEEP...	The lift is in the process of running auto return	■ ■ ■ ■ ■ ■ ■ ■ ...
Emergency stop pressed	The red emergency stop button has been pressed in. This must be released in order that the lift can function again	■ ■ ■ ■ ■ ■ ■ ■
The lift is locked	The lift is locked with a key switch	■ ■ ■ ■ ■ ■ ■ ■
Battery warning	Low battery level	■ ■ ■ ■ ■ ■ ■ ■
Power supply is interrupted – connect or press emergency stop	Connect to a power supply or activate emergency stop in order to power off the lift	■ ■ ■ ■ ■ ■ ■ ■

- ■ High tone followed a deeper tone
- ■ Low tone followed by higher tone
- ||| Identical tones (3 off)



10.9 Alarm and emergency call



The lift can be equipped with an alarm button (optional equipment) that can summon assistance. In order to activate the alarm, press on the alarm button and hold it in for approx. 5 seconds.

The alarm button can be connected in several ways:

1. The alarm button is connected to an alarm sensor in the lift that emits a high-pitch beeping tone that alerts others that there is a need for assistance at the lift.
2. The alarm button is connected to a call system that allows the user to contact external assistance, either using an analogue connection or by using a SIM card.



Preventive relay output



*Analogue connection
(SafeLine)*



*SIM card (SafeLine)
EMEA countries only*

SafeLine QR

More detailed information regarding the operation and functions of the SafeLine call system can be found here:

SafeLine MX3: <https://www.safeline-group.com/en/qg/mx3>

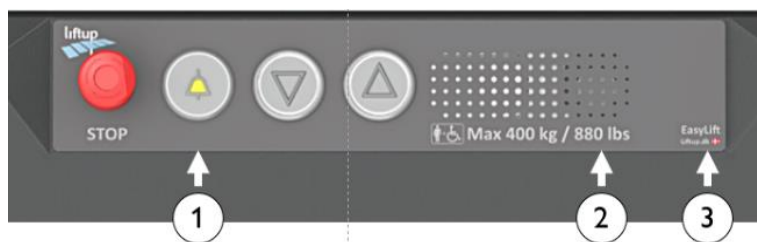

1. Alarm button (optional equipment)
2. Microphone
3. Status LED for communication module



11. Operation

Under normal operating conditions the lift shall always be connected to 100-240V (indoor)/90 – 305V (outdoor) electrical outlet. It is very important that the power is not disconnected or switched off, as long-standing power outage (10-20 hours) may result in flat batteries and thus inoperability. Thus the lift cannot be used until the batteries have been recharged. An audible alarm will sound if the power supply is interrupted (see section 10.8).

11.1 Battery backup

In the event of 110-240V power failure or if the control unit is for some other reason not supplied with power, the system will automatically switch to backup mode. This means the system will continue to function as normal since it is being powered by the battery backup. Mains power failure will be signaled by a beeping alarm sound; as soon as the mains is reconnected this alarm will cease. The system is now running as normal.

If it is not possible to re-establish the mains supply immediately and you wish to cancel the alarm, press the emergency stop button. (Note that in such a case the system will need to be calibrated, see section 11.2).



IMPORTANT!

If not connected to mains and the emergency button is not pressed, the batteries will finally be drained. In the event of a long-standing power outage, the emergency stop should be activated to ensure that the batteries are not completely discharged.



IMPORTANT!

If both the power supply has been disconnected and the emergency stop activated at the same time, the system will automatically switch to “safety mode” and will then need calibrating, see below.

11.2 Calibration following emergency stop/power failure

If the emergency stop has been activated and the power supply interrupted, or if the system registers any other form of irregularity, the lift must be calibrated. The lift automatically enters into a special “safety mode” that only allows it to move down at low speed until the lift reaches the lower level.



IMPORTANT!

If the lift does not operate as expected or stops again after a few inches/centimeters, technical problems may have arisen and require a repair by technical staff. Contact your dealer for further assistance.



12. Maintenance

Clean by wiping off with a cloth that has been wrung out in water containing a mild detergent.



IMPORTANT!

Do NOT use a high-pressure cleaner or wash the lift down with water straight from a hose. Aggressive detergents and suchlike must not be used on the lift. Also avoid salt or sand coming into contact with the lift in connection with winter maintenance.

The accompanying remote control (optional equipment) must be stored in a dry place and not be subjected to strong impacts by, for example, throwing it about. It must only be cleaned using a cloth that has been wrung out.

Perform regular checks under the lift for any leaves, branches or other items/objects and remove these in order to ensure it travels freely.

12.1 Replacement of battery in call stations/remote control

A CR2032 battery is installed in the wireless call stations, call station column (optional equipment) and remote control (optional equipment).



The battery must be replaced every two years to ensure stable operation.



BE SURE not to swallow the button battery and avoid putting the battery in your mouth due to the risk of swallowing it.



Keep the batteries out of the reach of small children. If a child swallows a battery, contact a doctor immediately.



Do not dispose of the battery together with unsorted household waste. When disposing of batteries, local provisions and regulations must be complied with.



How to replace the battery:

Hand-held remote control

1. Loosen the screw (Torx TX 6) on the rear of the remote control
2. Remove the rear panel
3. Replace the battery
4. Replace the rear panel and test the remote control



Call station

In order to gain access to the battery, loosen the 2 Torx screws and pull down the top cover to separate it from the body.

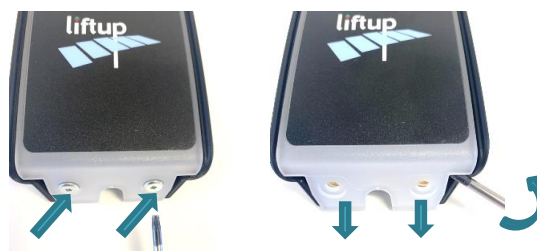

Call station column

To gain access to the battery, loosen the 4 screws and pull up the top cover carefully.



IMPORTANT!

Be careful not to disconnect the wires from each other. Pull the printed circuit out of the top cover carefully.

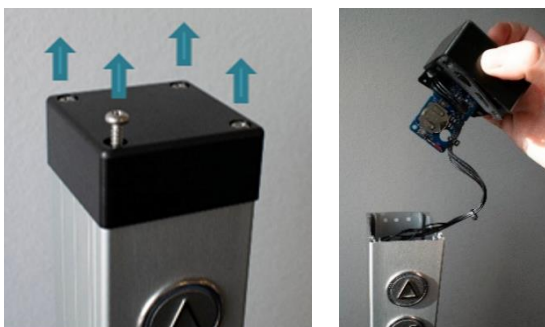

1. Replace the battery
2. Put the unit together in the reverse order and test the buttons.

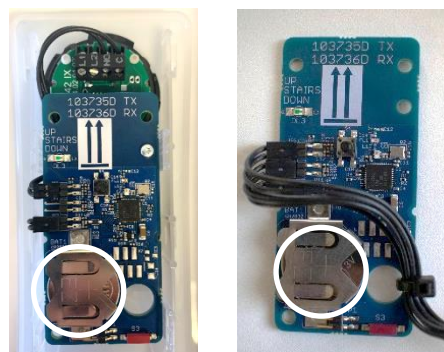

If the remote control or receiver has been without power for a long period of time, it may be necessary to calibrate the system (pair the two units), see section 13.



13. Pairing transmitter and receiver

13.1 Wireless call station/call station column 2.4 GHz

The transmitter and receiver must always be paired in order to work. This is normally done at the factory or by an authorized service technician. The receiver will not respond to a transmitter if it is not paired with. A receiver can be paired with up to 20 transmitters. A transmitter can be connected to several receivers if necessary.

How to pair the transmitter and receiver:

1. To gain access to S4 on the receiver, loosen the top screw and pull up the receiver "MODULE1" from the top of the wall profile.
2. Press briefly on S4 on the receiver and the control light (LED) will start to flash slowly. The receiver will now be in installation mode for 2 minutes.
3. Gaining access to the transmitter.

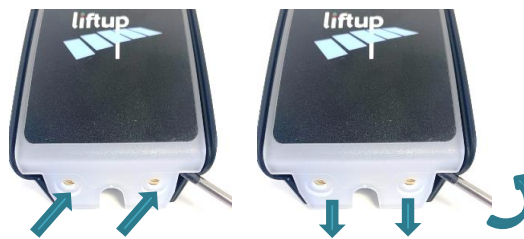

Call station

In order to gain access to the printed circuit board, loosen the 2 Torx screws and pull down the top cover to separate it from the body.

Call station column

To gain access to the printed circuit board containing the transmitter, loosen the 4 screws and pull up the top cover carefully. Pull the printed circuit out of the top cover carefully.

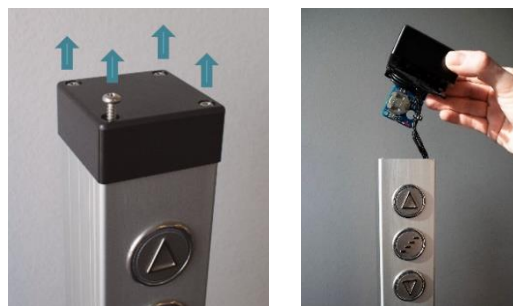

IMPORTANT!

Be careful not to disconnect the wires from each other. Pull the printed circuit out of the top cover carefully.



- The printed circuit containing the transmitter is now visible and should be briefly pressed at S4 in order to pair it with the receiver (must be done within 2 minutes).

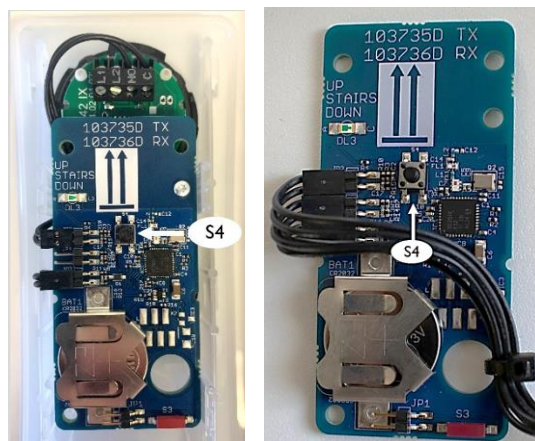

- Test the system to ensure that the pairing has been done correctly; if not, repeat points 1-4.
- If several remote controls are to be paired with the receiver, repeat from step 2 above.
- Replace the top cover

To reset a call station/call station pillar so that it is no longer paired with the lift, the following points should be followed:

How to reset the transmitter:

- Press S4 (2) on the transmitter for more than 10 seconds.
- Once the control light LED (1) starts to flash rapidly, the transmitter has been reset.



How to reset the receiver:

- Press S4 (2) on the receiver for more than 10 seconds.
- Once the control light LED starts to flash rapidly, the receiver has been reset.



13.2 Remote control 2.4 GHz (optional equipment)

The transmitter and receiver must always be paired in order to work. This is normally done at the factory or by an authorized service technician. The receiver will not respond to a transmitter without it having been paired with the receiver. A receiver can be paired with up to 20 transmitters. A transmitter can be paired with several receivers if necessary.

How to pair a transmitter and receiver:

1. To gain access to S4 on the 2.4 GHz receiver, loosen the top screw and pull up MODULE1 from the top of the wall profile.
2. Press briefly on S4 on the receiver and the control light will start to flash slowly. The receiver will now be in installation mode for 2 minutes.
3. Press the 'up arrow' (↑) and 'down arrow' (↓) on the remote control at the same time and hold them down for 5 seconds until the control light on the remote control starts to flash slowly. The remote control will now be in installation mode for 2 minutes. It should be flashing yellow. If it is flashing red, it is an 868 MHz model and is not suitable for the receiver.



Alternatively:

Press on Connect (S4), if the remote control is open.

4. Once the control light on the remote control stops flashing, it has been paired with the lift.
5. Test the system to ensure that the pairing has been performed correctly; if not, repeat 1-4 above.
6. Repeat from step 2 above if several remote controls are to be paired.

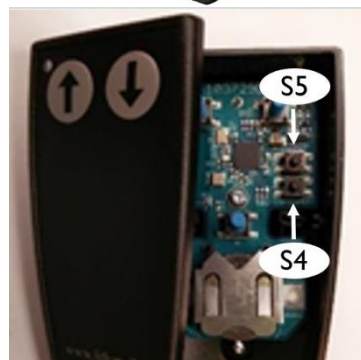

To reset a remote control so that it is no longer paired, the following points should be followed:

How to reset the transmitter:

1. Press the Up (↑) and DOWN (↓) buttons at the same time for 5 seconds until the control LED on the remote control starts to flash slowly.
2. The remote control is now in installation mode for 2 minutes. The following sequence must be performed within the 2-minute period:

Press: UP(↑), UP(↑), DOWN(↓), DOWN(↓), UP(↑), DOWN(↓), UP(↑), DOWN(↓)

If the sequence is performed correctly, the control light (LED) flashes rapidly 10 times.

Alternatively:

Press Reset (S5), if the remote control is open.

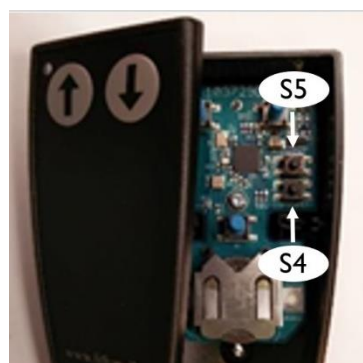

Test the system to ensure that the reset has been done properly and that the remote control is no longer paired. If not, repeat points 1-3 above.

How to reset the receiver:

1. Press S4 on the receiver for more than 10 seconds.
2. Once the control light starts to flash rapidly 10 times, the receiver has been reset.



14. Installation and handover

The installation and handover checklist below, which lists the lift's operating and safety functions, must be gone over with the user/owner of the lift before installation is concluded.



Installation and handover – EasyLift V3 Plus

Version: 1.0

Installation site		Product	
Name/Company		Product name	
Adress		Serial number	
Postal code/City		Installation date	
Contact person		Installed by	
Telephone no.		Customer accept	

Checklist:

No.	Description	Checked
1	Perform test with client, including control units, doors/barriers/ramp, full operation, emergency stop.	<input type="checkbox"/>
	Review of the manual with client, including:	
	Instruction of use	
2	• Operating units	<input type="checkbox"/>
3	• Key Switch On/Off	<input type="checkbox"/>
4	• Auto return functions	<input type="checkbox"/>
5	• Emergency stop	<input type="checkbox"/>
6	• ON/OFF switch for the charger and the effect on the battery	<input type="checkbox"/>
7	• Alarm and emergency call	<input type="checkbox"/>
8	• Parring operating units	<input type="checkbox"/>
	Safety instructions	
9	• Audible alarms	<input type="checkbox"/>
10	• Handling	<input type="checkbox"/>
11	• Warnings	<input type="checkbox"/>
12	• Overload	<input type="checkbox"/>
13	• Personal safety	<input type="checkbox"/>
14	• Anti-crushing	<input type="checkbox"/>
15	• Safety barriers	<input type="checkbox"/>
16	• Emergency evacuation	<input type="checkbox"/>
	Maintenance	
17	• Cleaning	<input type="checkbox"/>
18	• Replacement of battery in call stations	<input type="checkbox"/>
19	• Explain outdoor treatment: (no salt, no high-pressure water)	<input type="checkbox"/>
20	Inform the client about the legal requirements for statutory and service inspection.	<input type="checkbox"/>
21	Present the customer for the possible service agreements.	<input type="checkbox"/>
22	Update service log	<input type="checkbox"/>

Comments

lifting people

Liftup A/S | Hagensvej 21 | DK-9530 Støvring | Denmark | T: +45 9686 3020 | M: support@liftup.dk | CVR: DK-1015 3964



15. Inspection, checks and service inspections

In addition to the general maintenance described in section 12, regular service inspections and statutory checks and inspections of the lift must be carried out.



IMPORTANT!

For safety reasons, it is very important that these service inspections and statutory checks are complied with, as a lack of, or incorrectly performed, examinations, checks and inspections could result in personal injury.

15.1 Statutory inspection and checks

Statutory checks and inspections of the lift are to be carried out, as it is approved for the transport of people. It is the owner's responsibility and obligation to ensure that this is complied with.



IMPORTANT!

The number of statutory inspections depends on the legislation in the country in question.

15.2 Regular service inspections

As a manufacturer, we lay down requirements for regular service inspections of the lift to be carried out, see the interval stated below.



IMPORTANT!

The warranty may become void if the minimum requirement for service inspections is not observed.

The manufacturer's minimum requirements for number of service inspections per year

	Indoor	Outdoor
Private/not freely accessible	1	2
Public sector	2	4

As a producer, we recommend that the regular service inspection be carried out by an authorized service technician. The dealer from whom you have purchased the product will offer this service but, if you wish to use another service provider, it is the owner of the lift who will be responsible for the service technician chosen having received training on the product in question. See: <https://www.liftup.dk/en/contact>



IMPORTANT!

The emergency stop must be activated before servicing the lift. This is to protect against accidental operation. The service technician is responsible for the emergency stop being pressed before commencing the service.

NB: It is not sufficient to interrupt the power supply, as the system is equipped with a battery backup.



15.4 Service logbook

The form (like the example below) must be completed after each inspection.



Service logbook

Version: 3.0

Installation site		Product	
Name/Company		Product name	
Adress		Serialnumber	
Postcode / City		Installation date	
Contact person		Installed by	
Telephone no.			

Comments

No.	Date	Lognotes	Signature
1			
2			
3			
4			
5			
6			
7			
8			
9			
10			
12			
13			
14			
15			

lifting people

Liftup A/S | Hagensvej 21 | DK-9530 Støvring | Denmark | T: +45 9686 3020 | M: support@liftup.dk | CVR: DK-1015 3964



15.5 Online service log (only certain countries)

With a smart phone, tablet or similar, the QR code can be scanned. The QR code can be found on the label placed on the left side frame:



The CE label inserted in section 3 will provide you with the serial number of the specific lift as well as its QR code with direct access to the online service log. When scanning the QR code you access the online service log and a new log will be created. The fields must be filled out and the service technician/engineer/control authority enters an electronic acceptance after each visit.

Equipment Service Log

Equipment details 1

Serial no.: FS19-00010

Production year: 2019

Equipment type: 103141 Flexstep V2

Links to more information 2

[Link til produktvideo](#)

Equipment log 3

These are the recorded service log entries for the equipment.

Log no./IL	Log entry date	Created by	Log entry text	Comments	Signature
1	15/01/2019	PB	Installation/opstilling af lift	Liften er installeret. Intet avrigt at bemærke ifm. installationen.	PB
2	16/01/2019	Peter Pedersen	Opstillingskontrol	Liften er opstillingskontrolleret iht. bekendtgørelse, uden bemærkninger. Lifte må herefter tages i anvendelse	PP
3	13/02/2020	Hans Jensen	Årlig eftersyn	Årlig eftersyn gennemført iht. serviceaftale med Liftup A/S. Intet avrigt at bemærke.	HJ

[Add log entry](#)

1. Her kan du se udstyrsdetaljer såsom: serienummer, produktionsår med mere.

2. Klik på linket for at se en video om produktet

3. Dette er selve "log-bogen" for udstyret. Denne skal opdateres af serviceteknikeren ved hvert service besøg

4. Loggen skal udfyldes med dato, navn, en passende log entry tekst samt relevante kommentarer. Til slut underskrives loggen elektronisk.









16. Spare parts and accessories







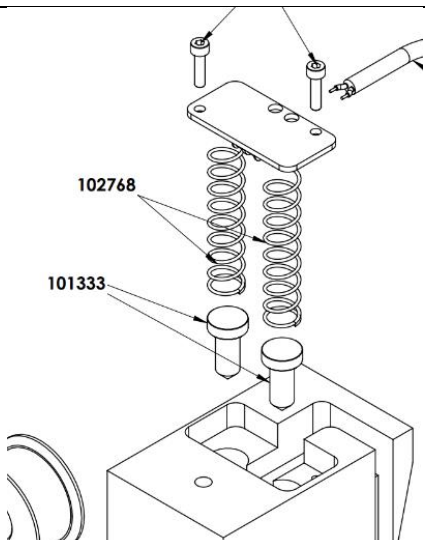

IMPORTANT! It is important to use only original spare parts. Replacement of parts may only be undertaken by an authorized service technician. The use of non-original spare parts may void the right of complaint. Furthermore, product safety may be compromised, which may pose a risk to personal safety.

For details regarding spare parts and service, please contact one of our dealers at: <https://www.liftup.dk/en/contact>

Article No.	Description	Illustration
100336	DC motor for Ramp	
100338	Micro Switch - Safety system - V4L IP67	
104834	Emergency Stop Button	
102744	Motor for Safety Barrier	
102759	POM guide for stairs/wall profile	
102766	Brush for wall profile	
102768	Spring for safety barrier contact	



Article No.	Description	Illustration
100579	Plug for door, 40x40 mm	
101139	Timing belt for vertical barrier (m)	
101326 103679	Actuator for door EasyLift 800/900 (grey) EasyLift 1100 (grey)	
102355 104179	Actuator for door EasyLift 800/900 (black) EasyLift 1100 (black)	
101558	Cable for vertical barrier/ call station	
103933	Remote control – transmitter unit (accessory)	
101951	Repair spray, Colour Akzo 900 sable	
103482	Control Board for FS2, ELV3	
102556	Cam for ramp lock FS2 & ELV3	
102557	Brass bracket for ramp lock FS2 & ELV3	



Article No.	Description	Illustration
103738	Print for connection board 2,4 GHz	
102773	Friction clutch for ramp lock	
102890	Battery 12V 5Ah LiFePo4 / FS2 / EL	
103080	Power supply unit 36 V (indoor)	
110005	Power supply unit 36 V (outdoor)	
103182	Actuator Complete, motor EasyLift V3	
103152	Spring for ramp - Friction clutch	
103333	Programming Cable USB A to B EasyLift	
101589	Micro Switch - Safety System Forced Break IP60 (EasyLift 800/900/1100)	

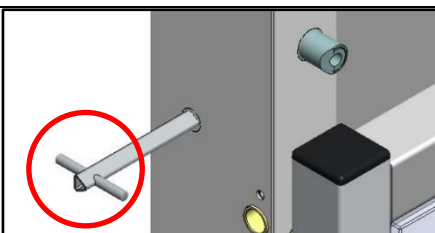

Article No.	Description	Illustration
103691	Triangular key for emergency opening of EasyLift 1100 door	

17. Disassembly

In order to ensure correct disassembly for any re-use in another installation, we recommend using an authorized service technician. Contact your dealer for assistance with disassembly.

Bear in mind that there may be a risk of overturning when the lift is detached from the building structure.

18. Disposal

The owner is responsible for disposing of the product in accordance with the rules applying at any time. Be particularly aware that batteries are fitted in the control unit and remote control and these need to be disposed of separately.



IMPORTANT!

Do not throw the batteries into the waste bin. When you dispose of batteries, local provisions and regulations must be complied with.

Where necessary, contact your dealer for assistance with disposal.

18.1 Material specification for EasyLift

Material	Included in the following components/parts ¹⁾
Steel (S 235 JR)	Frame, step, frames ²⁾ , handrails,
Aluminium (Al-Mg G3)	Ramp, cover plates, push plates, frames ²⁾ , step inserts
Brass (Cu Zn 39 Pb 3)	Bushings, gaskets, handrails
Plastic Polyoxymethylene (POM)	Handrail bushings, slide rails, bushings, gaskets
Plywood	Flooring
Electronics	Controls/PCB, lift columns
Copper	Cables

¹⁾ Call stations, call station columns and other external components are not included.

²⁾ Depending on the model, frames may be made of steel or aluminium.



19. Right of complaint

The right of complaint encompasses the at any time applicable rules regarding the right of complaint.

Liftup offers full right of complaint on spare parts for two years provided the product is registered with Liftup (<http://lpr.liftup.dk/>).

Product Registration

Register your product today and receive 2-years liability for defect on your product directly from Liftup.

Product ID - Serial no.	<input type="text" value="EL20"/>	<input type="text" value="00123"/>	
Type of registrant	<input type="text" value="Private User"/>		
First name	<input type="text"/>		
Last name	<input type="text"/>		
Organization	<input type="text"/>		
Address	<input type="text"/>		
City	<input type="text"/>		
Region / State	<input type="text"/>		
Zip Code	<input type="text"/>		
Phone	<input type="text" value="+ 1"/>	<input type="text"/>	
Email	<input type="text"/>		
Language	<input type="text" value="English"/>		
Copy of receipt	<input type="text" value="Vælg fil"/> Der er ingen fil valgt		

If you want to stay updated regarding the latest news and updates, please fill in the check box.

By registering your information, you agree that Liftup may keep your information in the 2-year period of Liability for defects and contact you upon updated user guides and product safety. When the period of Liability for defects has expired, we will contact you again to ask if we may retain your information. Otherwise they will be deleted. Additionally, this information is used for internal statistics, but is not disclosed to third parties. You can revoke your consent at any time.

For any questions regarding registration or liability for defects please contact mail@liftup.dk.



Please read more about this in the terms of sale and delivery:

<https://www.liftup.dk/en/about-liftup/general-conditions/>



NOTE: If the prescribed service inspections are not maintained, the right of complaint may be lost.

If the prescribed inspections, checks and service inspections are not observed, see section 0, this could have serious consequences for the safety of the product. It is the customer's responsibility to ensure that the product complies with the prescribed inspections, and service inspections at all times, see Order No 461 of 23 May 2016, Appendices 2 and 3 and the Danish Working Environment Authority's Order no. 1109, Section 14.





lifting people

We want to change the way people think about access products: More than a technology you need – it's a technology you want. We design thoughtful, holistic and aesthetic access solutions where every element adds to improve the total user experience. We create unique tailor-made solutions where our products help people and are fully and beautifully integrated in the architectural environment. This means that our access solutions also have an emotionally uplifting and satisfying impact – because they are comfortable, user-friendly and well-designed. This also means that we can transform access enablers from being tools that solves a task for the few – to being smart and pleasurable design elements for everyone to enjoy.

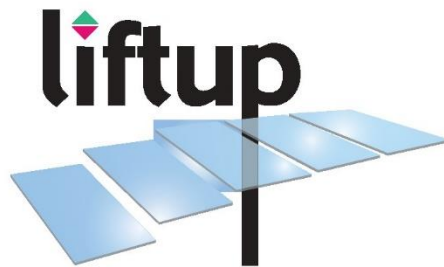

Distributed by:

WWW.LIFTUP.CO.UK